

ALPHA900 LINE - грили непосредственной жарки

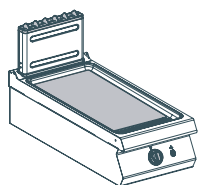
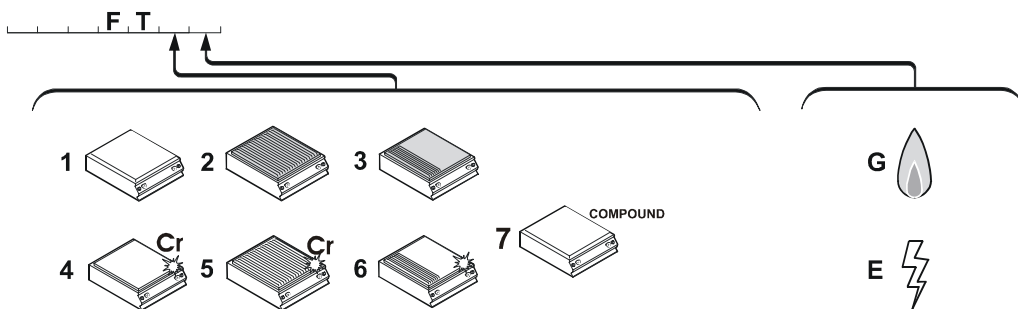

090FT1G

(8)

SMOOTH PLATE GAS GRIDDLE

18-10 stainless steel with 20/10 top. Satin finished Fe510D steel cooking plate. Heated by burner group controlled by modulating thermostat valve. Temperature control from 140 to 340°C.



cm. 40 x 90 x 24 h



kg. 60



m³ 0,31



kg. 65



kW | kcal/h | BTU
10 8600 34,120



kW
0,0006

Полезная площадь, дм 2

Удельное тепловыделение Вт/дм2

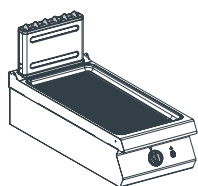

090FT2G

(8)

RIBBED PLATE GAS GRIDDLE

18-10 stainless steel with 20/10 top. Satin finished Fe510D steel cooking plate. Heated by burner group controlled by modulating thermostat valve. Temperature control from 140 to 340°C.



cm. 40 x 90 x 24 h



kg. 60



m³ 0,31



kg. 65



kW | kcal/h | BTU
10 8600 34,120



kW
0,0006

Полезная площадь, дм 2

Удельное тепловыделение Вт/дм2

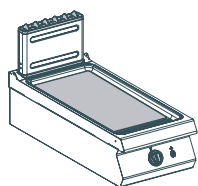

090FT4G

(8)

SMOOTH CHROMIUM PLATED GAS GRIDDLE

18-10 stainless steel with 20/10 top. Griddle plate in Fe510 D steel, with hard chromium surface treatment, heated by burner group controlled by modulating thermostat valve with safety thermostat. Temperature control from 120° to 280°C.



cm. 40 x 90 x 24 h



kg. 60



m³ 0,31



kg. 65



kW | kcal/h | BTU
10 8600 34,120



kW
0,0006

Полезная площадь, дм 2

Удельное тепловыделение Вт/дм2

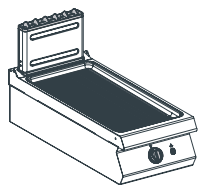

090FT5G

(8)

RIBBED CHROMIUM PLATED GAS GRIDDLE

18-10 stainless steel with 20/10 top. Griddle plate in Fe510 D steel, with hard chromium surface treatment, heated by burner group controlled by modulating thermostat valve with safety thermostat. Temperature control from 120° to 280°C.



cm. 40 x 90 x 24 h



kg. 60



m³ 0,31



kg. 65



kW | kcal/h | BTU
10 8600 34,120



kW
0,0006

Полезная площадь, дм 2

Удельное тепловыделение Вт/дм2

Представительство на территории РФ:



Для корреспонденции: п/я 7, 119571, Москва, Россия.
Адрес выставочного зала: 23, Миклухо-Маклая, Москва, Россия.
Телефоны: 007+495+1013986, 9569580, 9569985.

Факс: 007+499+9362323.
Email: gabel@dol.ru.
www.angelopo.ru



ALPHA900 LINE - грили непосредственной жарки

	090FT7G (8)	SMOOTH COMPOUND PLATE GAS GRIDDLE 18-10 stainless steel with 20/10 top. Satin finished compound (Aisi316L+FE) s/steel cooking plate. Heated by burner group controlled by modulating thermostat valve. Temperature control from 140 to 340°C.	cm. 40 x 90 x 24 h m ³ 0,31 kg. 60 kg. 65 kW kcal/h BTU 10 8600 34,120 kW 0,0006
Полезная площадь, дм 2		Удельное тепловыделение Вт/дм2	
	190FT1G (8)	SMOOTH PLATE GAS GRIDDLE 18-10 stainless steel with 20/10 top. Satin finished Fe510D steel cooking plate. Heated by two burner groups controlled by modulating thermostat valve. Temperature control from 140 to 340°C.	cm. 80 x 90 x 24 h m ³ 0,6 kg. 80 kg. 85 kW kcal/h BTU 20 17200 68,240 kW 0,0006
Полезная площадь, дм 2		Удельное тепловыделение Вт/дм2	
	190FT2G (8)	RIBBED PLATE GAS GRIDDLE 18-10 stainless steel with 20/10 top. Satin finished Fe510D steel cooking plate. Heated by two burner groups controlled by modulating thermostat valve. Temperature control from 140 to 340°C.	cm. 80 x 90 x 24 h m ³ 0,6 kg. 80 kg. 85 kW kcal/h BTU 20 17200 68,240 kW 0,0006
Полезная площадь, дм 2		Удельное тепловыделение Вт/дм2	
	190FT3G (8)	RIBBED/SMOOTH PLATE GAS GRIDDLE 18-10 stainless steel with 20/10 top. Satin finished Fe510D steel cooking plate. Heated by two burner groups controlled by modulating thermostat valve. Temperature control from 140 to 340°C.	cm. 80 x 90 x 24 h m ³ 0,6 kg. 80 kg. 85 kW kcal/h BTU 20 17200 68,240 kW 0,0006
Полезная площадь, дм 2		Удельное тепловыделение Вт/дм2	
	190FT4G (8)	SMOOTH CHROMIUM PLATED GAS GRIDDLE 18-10 stainless steel with 20/10 top. Griddle plate in Fe510 D steel, with hard chromium surface treatment, heated by independent burner group controlled by modulating thermostat valve with safety thermostat. Temperature control from 120° to 280°C.	cm. 80 x 90 x 24 h m ³ 0,6 kg. 80 kg. 85 kW kcal/h BTU 20 17200 68,240 kW 0,0006
Полезная площадь, дм 2		Удельное тепловыделение Вт/дм2	

Представительство на территории РФ:



Для корреспонденции: п/я 7, 119571, Москва, Россия.
Адрес выставочного зала: 23, Миклухо-Маклая, Москва, Россия.
Телефоны: 007+495+1013986, 9569580, 9569985.

Факс: 007+499+9362323.
Email: gabel@dol.ru.
www.angelopo.ru



ALPHA900 LINE - грили непосредственной жарки

	190FT6G (8)	RIBBED/SMOOTH CHROMIUM PLATED GAS GRIDDLE 18-10 stainless steel with 20/10 top. Griddle plate in Fe510 D steel, with hard chromium surface treatment, heated by two independent burner groups controlled by modulating thermostat valve with safety thermostat. Temperature control from 120° to 280°C.	cm. 80 x 90 x 24 h kg. 80 m³ 0,6 kg. 85 kW kcal/h BTU 20 17200 68,240 kW 0,0006
Полезная площадь, дм 2		Удельное тепловыделение Вт/дм2	
	190FT7G (8)	SMOOTH COMPOUND PLATE GAS GRIDDLE 18-10 stainless steel with 20/10 top. Satin finished compound (Aisi316L+FE) s/steel cooking plate Heated by two independent burner groups controlled by modulating thermostat valve. Temperature control from 140 to 340°C.	cm. 80 x 90 x 24 h kg. 80 m³ 0,6 kg. 85 kW kcal/h BTU 20 17200 68,240 kW 0,0006
Полезная площадь, дм 2		Удельное тепловыделение Вт/дм2	
	090FT1E (12)	SMOOTH PLATE ELECTRIC GRIDDLE 18-10 stainless steel with 20/10 top. Satin finished Fe510D steel cooking plate. Heating with elements below the plate in AISI 304L stainless steel. Thermostat temperature control 100° to 270°C and safety thermostat.	cm. 40 x 90 x 24 h kg. 60 m³ 0,31 kg. 65 kW 6,6
Полезная площадь, дм 2		Удельное тепловыделение Вт/дм2	
	090FT2E (12)	RIBBED PLATE ELECTRIC GRIDDLE 18-10 stainless steel with 20/10 top. Satin finished Fe510D steel cooking plate. Heating with elements below the plate in AISI 304L stainless steel. Thermostat temperature control 100° to 270°C and safety thermostat.	cm. 40 x 90 x 24 h kg. 60 m³ 0,31 kg. 65 kW 6,6
Полезная площадь, дм 2		Удельное тепловыделение Вт/дм2	
	090FT4E (12)	SMOOTH CHROMIUM PLATED ELECTRIC GRIDDLE 18-10 stainless steel with 20/10 top. Griddle plate in Fe510D, with hard chromium surface treatment. Heating with elements below the plate in AISI 304L stainless steel. Thermostat temperature control 100-270°C, and safety thermostat.	cm. 40 x 90 x 24 h kg. 60 m³ 0,31 kg. 65 kW 6,6
Полезная площадь, дм 2		Удельное тепловыделение Вт/дм2	

Представительство на территории РФ:



Для корреспонденции: п/я 7, 119571, Москва, Россия.
 Адрес выставочного зала: 23, Миклухо-Маклая, Москва, Россия.
 Телефоны: 007+495+1013986, 9569580, 9569985.

Факс: 007+499+9362323.
 Email: gabel@dol.ru.
 www.angelopo.ru



ALPHA900 LINE - грили непосредственной жарки

	090FT5E (12)	RIBBED CHROMIUM PLATED ELECTRIC GRIDDLE 18-10 stainless steel with 20/10 top. Griddle plate in Fe510D, with hard chromium surface treatment. Heating with elements below the plate in AISI 304L stainless steel. Thermostat temperature control 100-270°C, and safety thermostat.	 cm. 40 x 90 x 24 h kg. 60 m³ 0,31 kg. 65 kW 6,6
Полезная площадь, дм 2		Удельное тепловыделение Вт/дм2	
	090FT7E (12)	SMOOTH COMPOUND PLATE ELECTRIC GRIDDLE 18-10 stainless steel with 20/10 top. Satin finished compound (Aisi316L+FE) s/steel cooking plate. Heating with elements below the plate in AISI 304L s/steel. Thermostat temperature control 100° to 270°C and safety thermostat.	 cm. 40 x 90 x 24 h kg. 60 m³ 0,31 kg. 65 kW 6,6
Полезная площадь, дм 2		Удельное тепловыделение Вт/дм2	
	190FT1E (12)	SMOOTH PLATE ELECTRIC GRIDDLE 18-10 stainless steel with 20/10 top. Satin finished Fe510D steel cooking plate. Heating with two groups of elements below the plate in AISI 304L stainless steel. Thermostat temperature control 100° to 270°C and safety thermostat.	 cm. 80 x 90 x 24 h kg. 80 m³ 0,6 kg. 85 kW 13,2
Полезная площадь, дм 2		Удельное тепловыделение Вт/дм2	
	190FT2E (12)	RIBBED PLATE ELECTRIC GRIDDLE 18-10 stainless steel with 20/10 top. Satin finished Fe510D steel cooking plate. Heating with two groups of elements below the plate in AISI 304L stainless steel. Thermostat temperature control 100° to 270°C and safety thermostat.	 cm. 80 x 90 x 24 h kg. 80 m³ 0,6 kg. 85 kW 13,2
Полезная площадь, дм 2		Удельное тепловыделение Вт/дм2	
	190FT3E (12)	RIBBED/SMOOTH PLATE ELECTRIC GRIDDLE 18-10 stainless steel with 20/10 top. Satin finished Fe510D steel cooking plate. Heating with two groups of elements below the plate in AISI 304L stainless steel. Thermostat temperature control 100° to 270°C and safety thermostat.	 cm. 80 x 90 x 24 h kg. 80 m³ 0,6 kg. 85 kW 13,2
Полезная площадь, дм 2		Удельное тепловыделение Вт/дм2	

Представительство на территории РФ:



Для корреспонденции: п/я 7, 119571, Москва, Россия.
Адрес выставочного зала: 23, Миклухо-Маклая, Москва, Россия.
Телефоны: 007+495+1013986, 9569580, 9569985.

Факс: 007+499+9362323.
Email: gabel@dol.ru.
www.angelopo.ru



ALPHA900 LINE - грили непосредственной жарки

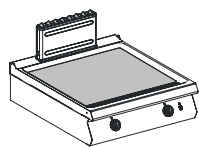

190FT4E
(12)

SMOOTH CHROMIUM PLATED ELECTRIC GRIDDLE

18-10 stainless steel with 20/10 top.
Griddle plate in Fe510D, with hard chromium surface treatment. Heating with two groups of elements below the plate in AISI 304L stainless steel. Thermostat temperature control 100-270°C, and safety thermostat.



cm. 80 x 90 x 24 h



kg. 80



m³ 0,6



kg. 85



kW
13,2

Полезная площадь, дм 2

Удельное тепловыделение Вт/дм2

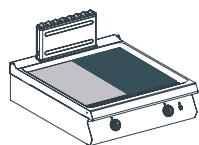

190FT6E
(12)

RIBBED/SMOOTH CHROMIUM PLATED ELECTRIC GRIDDLE

18-10 stainless steel with 20/10 top.
Griddle plate in Fe510D, with hard chromium surface treatment. Heating with two groups of elements below the plate in AISI 304L stainless steel. Thermostat temperature control 100-270°C, and safety thermostat.



cm. 80 x 90 x 24 h



kg. 80



m³ 0,6



kg. 85



kW
13,2

Полезная площадь, дм 2

Удельное тепловыделение Вт/дм2

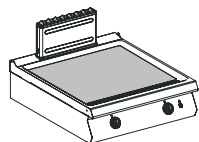

190FT7E
(12)

SMOOTH COMPOUND PLATE ELECTRIC GRIDDLE

18-10 stainless steel with 20/10 top.
Satin finished compound (Aisi316L+FE) s/steel cooking plate. Heating with two groups of elements below the plate in AISI 304L s/steel. Thermostat temperature control 100° to 270°C and safety thermostat.



cm. 80 x 90 x 24 h



kg. 80



m³ 0,6



kg. 85



kW
13,2

Полезная площадь, дм 2

Удельное тепловыделение Вт/дм2

Представительство на территории РФ:



Для корреспонденции: п/я 7, 119571, Москва, Россия.
Адрес выставочного зала: 23, Миклухо-Маклая, Москва, Россия.
Телефоны: 007+495+1013986, 9569580, 9569985.

Факс: 007+499+9362323.
Email: gabel@dol.ru.
www.angelopo.ru



ALPHA900 LINE - грили непосредственной жарки подготовленные для установки со стендом.

	091FT1E (12) € 2.331	SMOOTH PLATE ELECTRIC GRIDDLE 18-10 stainless steel with 20/10 top.Satin finished Fe510D steel cooking plate.Heating with elements below the plate in AISI304L stainless steel.Thermostat temperature control 100° to 270°C,safety thermostat,remote control of power peaks.Open under cabinet.	 cm. 40 x 90 x 72 h	 kW 6,6
Полезная площадь, дм 2		Удельное тепловыделение Вт/дм2		
	091FT2E (12) € 2.481	RIBBED PLATE ELECTRIC GRIDDLE 18-10 stainless steel with 20/10 top. Satin finished Fe510D steel cooking plate. Heating with elements below the plate in AISI 304L stainless steel. Thermostat temperature control 100° to 270°C, safety thermostat,remote control of power peaks.Open under cabinet.	 cm. 40 x 90 x 72 h	 kW 6,6
Полезная площадь, дм 2		Удельное тепловыделение Вт/дм2		
	091FT4E (12) € 2.611	SMOOTH CHROMIUM PLATED ELECTRIC GRIDDLE 18-10 stainless steel with 20/10 top.Griddle plate in Fe510D, with hard chromium surface treatment. Heating with elements below the plate in AISI 304L stainless steel.Thermostat temperature control 100-270°C,safety thermostat,remote control of power peaks.Open under cabinet.	 cm. 40 x 90 x 72 h	 kW 6,6
Полезная площадь, дм 2		Удельное тепловыделение Вт/дм2		
	091FT5E (12) € 2.676	RIBBED CHROMIUM PLATED ELECTRIC GRIDDLE 18-10 stainless steel with 20/10 top.Griddle plate in Fe510D, with hard chromium surface treatment. Heating with elements below the plate in AISI 304L stainless steel.Thermostat temperature control 100-270°C,safety thermostat,remote control of power peaks.Open under cabinet.	 cm. 40 x 90 x 72 h	 kW 6,6
Полезная площадь, дм 2		Удельное тепловыделение Вт/дм2		
	091FT7E (12) € 2.498	SMOOTH COMPOUND PLATE ELECTRIC GRIDDLE 18-10 stainless steel with 20/10 top.Satin finished compound (Aisi316L+FE) s/steel cooking plate.Heating with elements below the plate in AISI304L s/steel. Thermostat temperature control 100° to 270°C,safety thermostat,remote control of power peaks.Open under cabinet.	 cm. 40 x 90 x 72 h	 kW 6,6
Полезная площадь, дм 2		Удельное тепловыделение Вт/дм2		

Представительство на территории РФ:



Для корреспонденции: п/я 7, 119571, Москва, Россия.
 Адрес выставочного зала: 23, Миклухо-Маклая, Москва, Россия.
 Телефоны: 007+495+1013986, 9569580, 9569985.

Факс: 007+499+9362323.
 Email: gabel@dol.ru.
 www.angelopo.ru



ALPHA900 LINE - грили непосредственной жарки подготовленные для установки со стендом.

	191FT1E (12)	SMOOTH PLATE ELECTRIC GRIDDLE 18-10 stainless steel with 20/10 top.Satin finished Fe510D steel cooking plate. Heating with two groups of elements below the plate in AISI304L stainless steel.Thermostat temperature control 100° to 270°C,safety thermostat,remote control of power peaks.Open under cabinet.	 cm. 80 x 90 x 72 h	 kW 13,2
Полезная площадь, дм 2		Удельное тепловыделение Вт/дм2		
	191FT2E (12)	RIBBED PLATE ELECTRIC GRIDDLE 18-10 stainless steel with 20/10 top.Satin finished Fe510D steel cooking plate.Heating with two groups of elements below the plate in AISI304L stainless steel.Thermostat temperature control 100° to 270°C,safety thermostat,remote control of power peaks .Open under cabinet.	 cm. 80 x 90 x 72 h	 kW 13,2
Полезная площадь, дм 2		Удельное тепловыделение Вт/дм2		
	191FT3E (12)	RIBBED/SMOOTH PLATE ELECTRIC GRIDDLE 18-10 stainless steel with 20/10 top.Satin finished Fe510D steel cooking plate.Heating with two groups of elements below the plate in AISI304L stainless steel.Thermostat temperature control 100° to 270°C,safety thermostat,remote control of power peaks.Open under cabinet.	 cm. 80 x 90 x 72 h	 kW 13,2
Полезная площадь, дм 2		Удельное тепловыделение Вт/дм2		
	191FT4E (12)	SMOOTH CHROMIUM PLATED ELECTRIC GRIDDLE 18-10 stainless steel with 20/10 top.Griddle plate in Fe510D, with hard chromium surface treatment. Heating with elements below the plate in AISI 304L stainless steel.Thermostat temperature control 100-270°C,safety thermostat,remote control of power peaks.Open under cabinet.	 cm. 80 x 90 x 72 h	 kW 13,2
Полезная площадь, дм 2		Удельное тепловыделение Вт/дм2		
	191FT6E (12)	RIBBED/SMOOTH CHROMIUM PLATED ELECTRIC GRIDDLE 18-10 stainless steel with 20/10 top.Griddle plate in Fe510D, with hard chromium surface treatment. Heating with elements below the plate in AISI 304L stainless steel.Thermostat temperature control 100-270°C,safety thermostat,remote control of power peaks.Open under cabinet.	 cm. 80 x 90 x 72 h	 kW 13,2
Полезная площадь, дм 2		Удельное тепловыделение Вт/дм2		

Представительство на территории РФ:



с 1990 года

Для корреспонденции: п/я 7, 119571, Москва, Россия.
Адрес выставочного зала: 23, Миклухо-Маклая, Москва, Россия.
Телефоны: 007+495+1013986, 9569580, 9569985.

Факс: 007+499+9362323.
Email: gabel@dol.ru.
www.angelopo.ru



ALPHA900 LINE - грили непосредственной жарки подготовленные для установки со стендом.

	191FT7E (12)	SMOOTH COMPOUND PLATE ELECTRIC GRIDDLE 18-10 stainless steel with 20/10 top.Satin finished compound (Aisi316L+FE) s/steel cooking plate.Heating with elements below the plate in AISI304L s/steel. Thermostat temperature control 100° to 270°C,safety thermostat,remote control of power peaks.Open under cabinet.	 cm. 80 x 90 x 72 h	 kW 13.2
Полезная площадь, дм 2		Удельное тепловыделение Вт/дм2		
	09PS	Ограждение от брызг для модуля шириной 40 см Splash guard strips 18-10 in stainless steel, satin finish. Comprising three removable sections to facilitate cleaning.		
	19PS	Ограждение от брызг для модуля шириной 80 см Splash guard strips in 18-10 stainless steel, satin finish. Comprising three removable sections to facilitate cleaning.		
	RFT	Скребок Scraper tool for griddle, with ergonomic handle, to be fitted with smooth blade. Particularly suitable for cleaning chromium plated griddle.	 m³ 0	 kg 0,25 kg. 0,3
	KLL	Набор 10-ти лезвий Set of ten smooth blades for griddle plate scrapers. Particularly suitable for cleaning chromium plated griddles.	 m³ 0	

Представительство на территории РФ:



Для корреспонденции: п/я 7, 119571, Москва, Россия.
 Адрес выставочного зала: 23, Миклухо-Маклая, Москва, Россия.
 Телефоны: 007+495+1013986, 9569580, 9569985.

Факс: 007+499+9362323.
 Email: gabel@dol.ru.
 www.angelopo.ru